

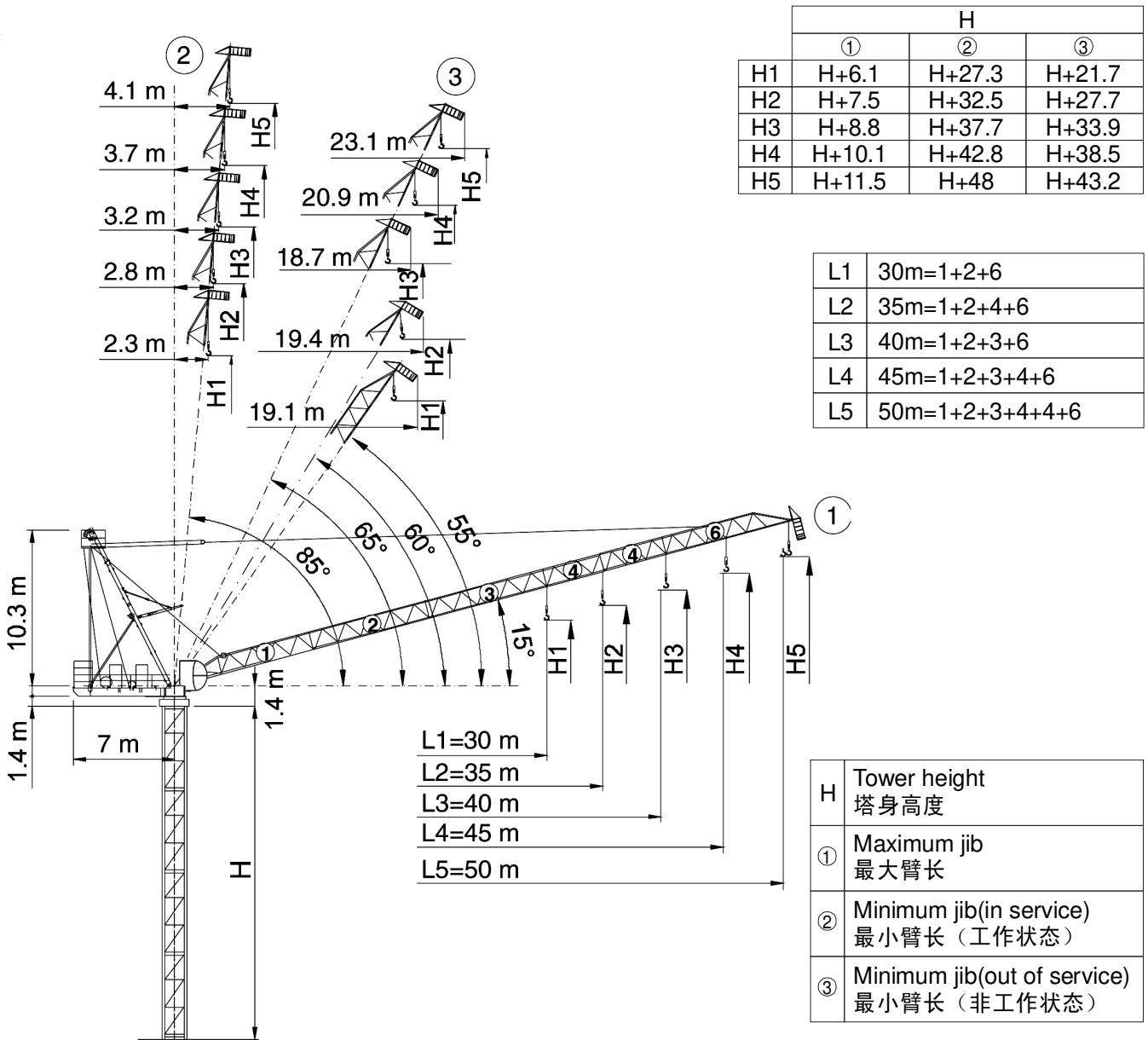

Jt L40 F8



Jt L40 F8

塔身 Masts

L68A1

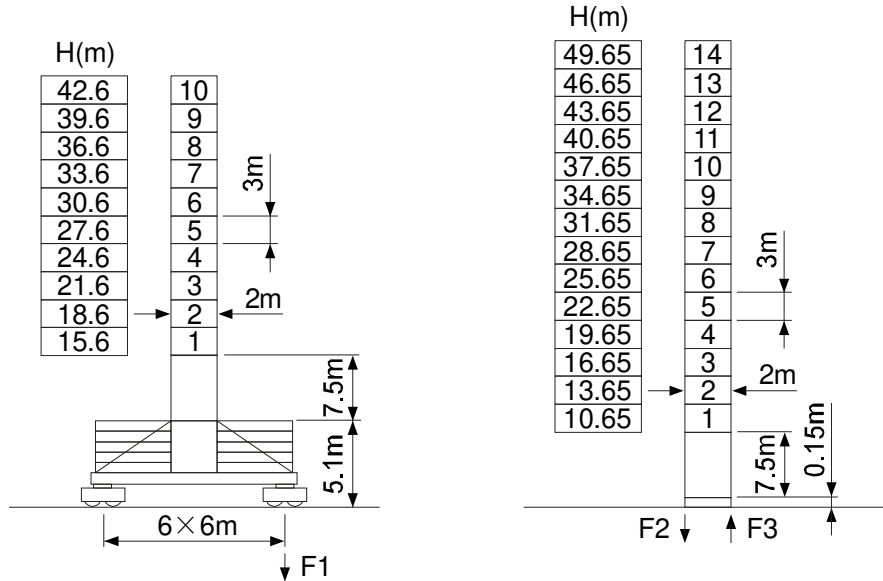

L46A1

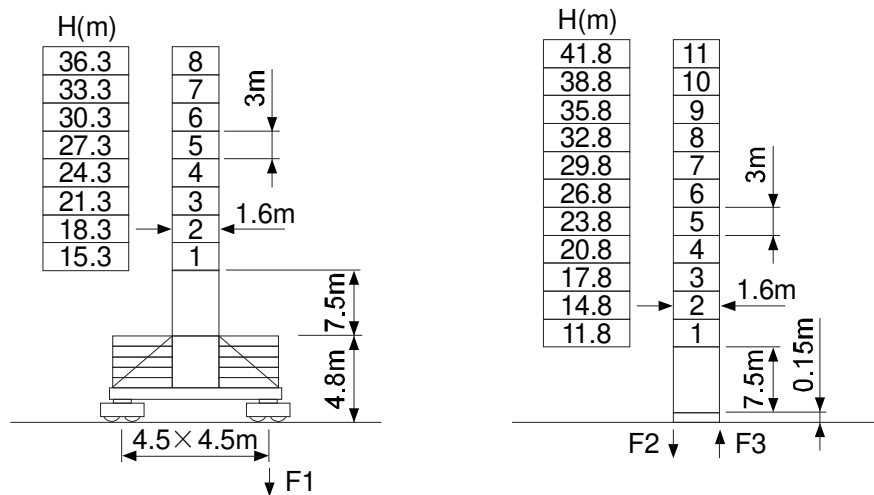





※ 请联系我们 Please consult us.

● 工作状态 In service F 反力 Reactions ■ 非工作状态 Out of service ☎ 自重 Without load and ballast with longest jib and maximum height

Jt L140 F8

负荷特性 Load diagrams

  		m	15	20	25	30	35	40	45	50
4t	- 32.8m	t	4	4	4	4	3.6	2.85	2.27	1.8
4t	- 33.8m	t	4	4	4	4	3.78	3	2.4	※
6t	- 26.1m	t	6	6	6	4.92	3.88	3.1	2.5	
8t	- 20.8m	t	8	8	6.25	4.81	3.78	3	2.4	
4t	- 34.8m	t	4	4	4	4	3.97	3.2	※	
6t	- 26.7m	t	6	6	6	5.11	4.07	3.3		
8t	- 21.2m	t	8	8	6.45	5.01	3.97	3.2		
4t	- 35m	t	4	4	4	4	4			
6t	- 27.4m	t	6	6	6	5.33	4.3			
8t	- 21.7m	t	8	8	6.68	5.23	4.2			
4t	- 30m	t	4	4	4	4				
6t	- 28m	t	6	6	6	5.5				
8t	- 22m	t	8	8	6.84	5.4				

※ = +200kg (  45m-40m)

内爬与附着 Climbing & Anchorages

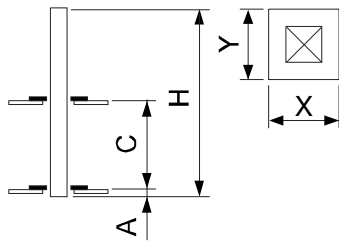

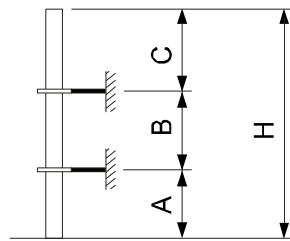

※ 请联系我们 Please consult us.



※ 请联系我们 Please consult us.

Jt L140 F8

机构 Mechanisms

			m/min	t	kW	绕绳量 Rope length
起升 Hoisting	40LVF20		0~40	4	30kW	400m >400m※
			40~80	2		
			0~30	6		
			30~60	3		
			0~20	8		
			20~40	4		
拉臂 Luffing	※	※		※		
回转 Slewing	RCV95	0~0.8r/min		2×95Nm		
行走 Traveling	RT443	12.1/24.1m/min		4×3.4/1.7kW		
380V(+6%~10%) 50Hz			※			

※ 请联系我们 Please consult us.



Jt L140 F10

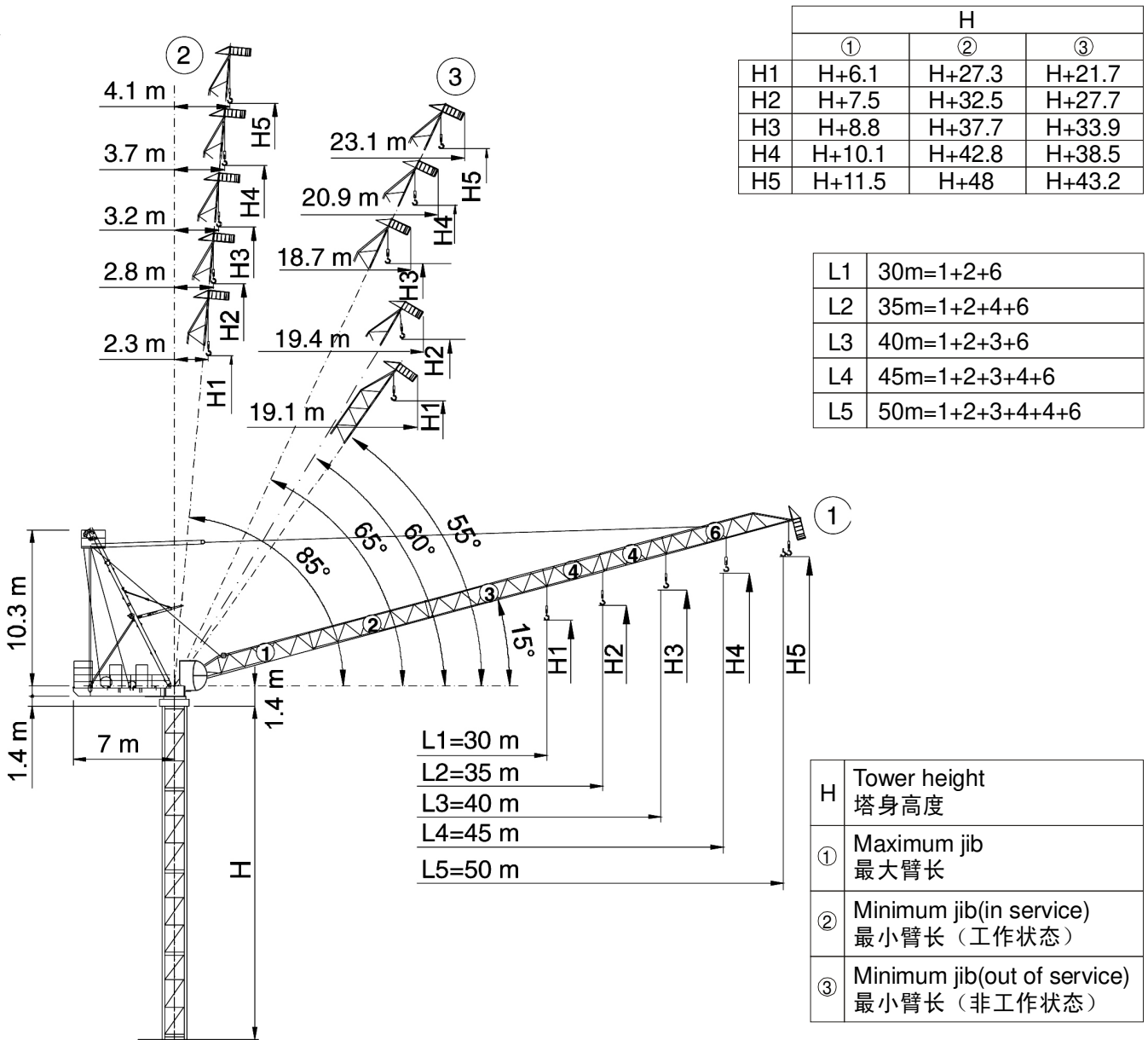

Jt L40 F10

塔身 Masts

L68A1

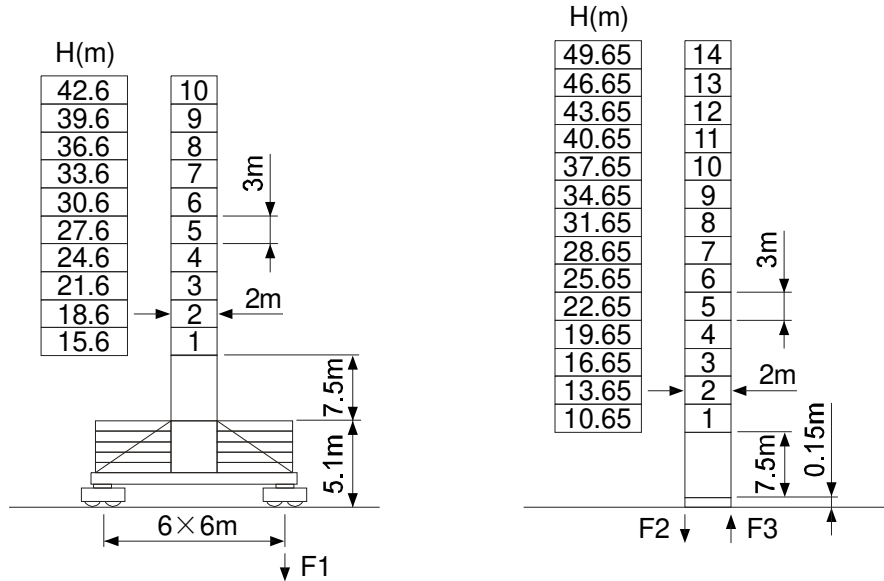

L46A1

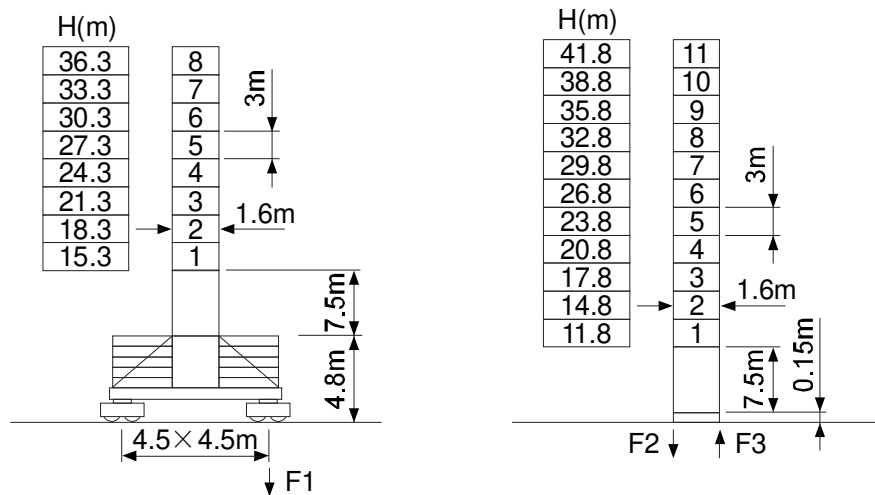







※ 请联系我们 Please consult us.

● 工作状态 In service F 反力 Reactions ■ 非工作状态 Out of service ☎ 自重 Without load and ballast with longest jib and maximum height

Jt L140 F10

负荷特性 Load diagrams

				m	15	20	25	30	35	40	45	50
5t	-	28.4m	t	5	5	5	4.61	3.6	2.85	2.27	1.8	
5t	-	29.2m	t	5	5	5	4.81	3.78	3	2.4	※	
7.5t	-	22.1m	t	7.5	7.5	6.36	4.92	3.88	3.1	2.5		
10t	-	20.8m	t	10	8.42	6.25	4.81	3.78	3	2.4		
5t	-	30m	t	5	5	5	5	3.97	3.2	※		
7.5t	-	22.5m	t	7.5	7.5	6.56	5.11	4.07	3.3			
10t	-	17.7m	t	10	8.64	6.45	5.01	3.97	3.2			
5t	-	31m	t	5	5	5	5	4.2	※			
7.5t	-	23.1m	t	7.5	7.5	6.78	5.33	4.3				
10t	-	18.1m	t	10	8.85	6.68	5.23	4.2				
5t	-	30m	t	5	5	5	5					
7.5t	-	23.5m	t	7.5	7.5	6.95	5.5					
10t	-	18.3m	t	10	9.02	6.84	5.4					

※ = +200kg (  45m-40m-35m)

内爬与附着 Climbing & Anchorages

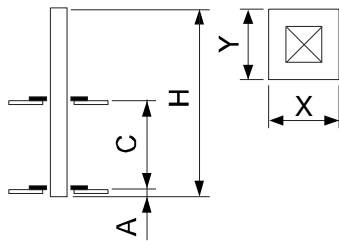



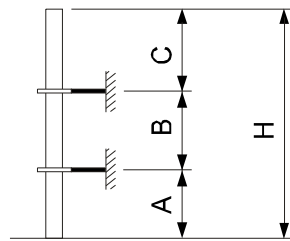



※ 请联系我们 Please consult us.



※ 请联系我们 Please consult us.

Jt L140 F10

机构 Mechanisms

			m/min	t	kW	绕绳量 Rope length
△ 起升 Hoisting	55RCS25		0~42	5	41kW	500m >500m※
			0~85	2.5		
			0~31.5	7.5		
			0~63	3.75		
			0~21	10		
	0~42		5			
	55LVF25		0~45	5	45kW	550m >550m※
			45~90	2.5		
			0~33	7.5		
			33~67.5	3.75		
		0~22	10			
	22~45	5				

拉臂 Luffing	※	※	※
回转 Slewing	RCV95	0~0.8r/min	2×95Nm
行走 Traveling	RT443	12.1/24.1m/min	4×3.4/1.7kW

380V(+6%~10%) 50Hz	※
--------------------	---

※ 请联系我们 Please consult us.

△ 可选 Option



Jt L180 G16 H20

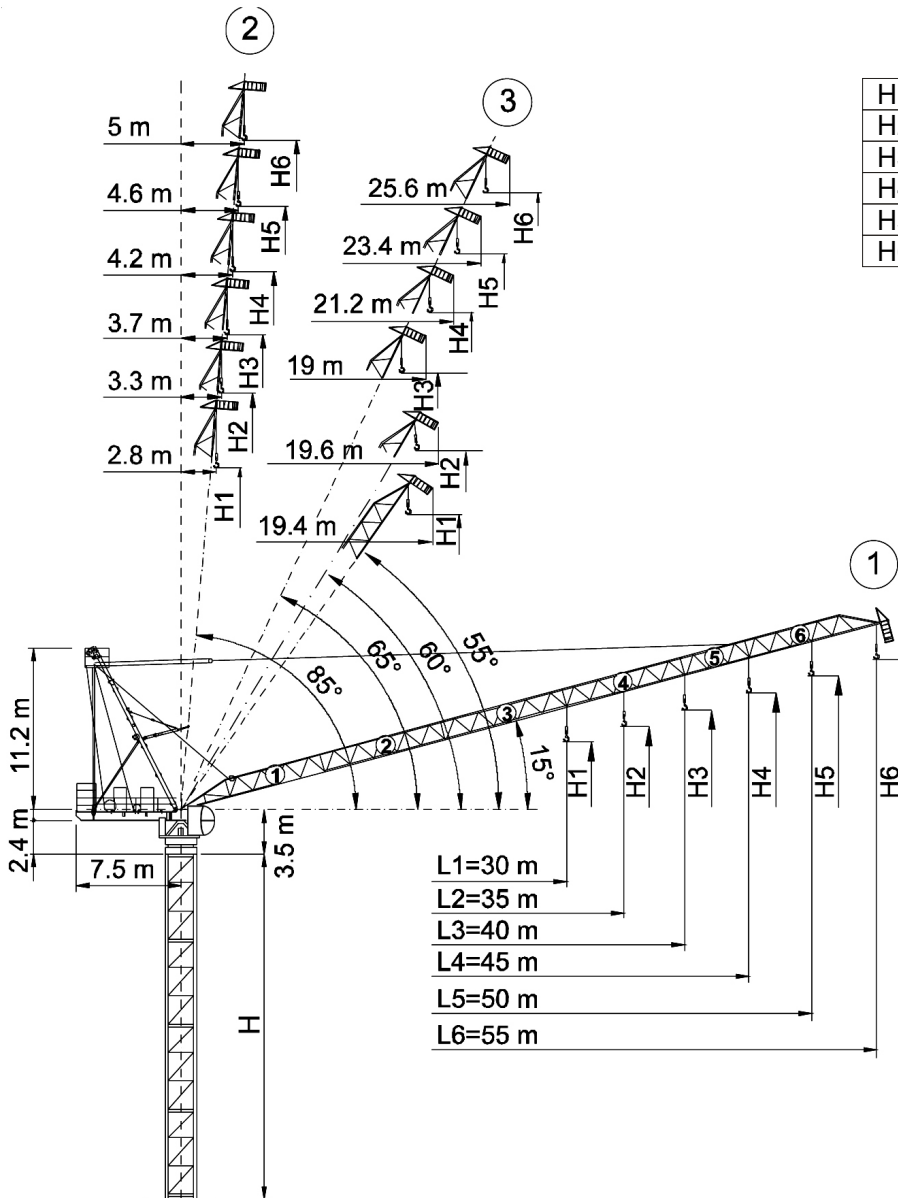

	H		
	①	②	③
H1	H+8.1	H+28.8	H+23.3
H2	H+9.4	H+34	H+29.2
H3	H+10.7	H+39.2	H+35.4
H4	H+12.1	H+44.4	H+40.1
H5	H+13.4	H+49.5	H+44.8
H6	H+14.7	H+54.6	H+49.5

L1	30m=1+2+6
L2	35m=1+2+5+6
L3	40m=1+2+3+6
L4	45m=1+2+3+5+6
L5	50m=1+2+3+4+6
L6	55m=1+2+3+4+5+6

H	Tower height 塔身高度
①	Maximum jib 最大臂长
②	Minimum jib(in service) 最小臂长 (工作状态)
③	Minimum jib(out of service) 最小臂长 (非工作状态)

Jt L 18 0 G16 H20

塔身 Masts

H20

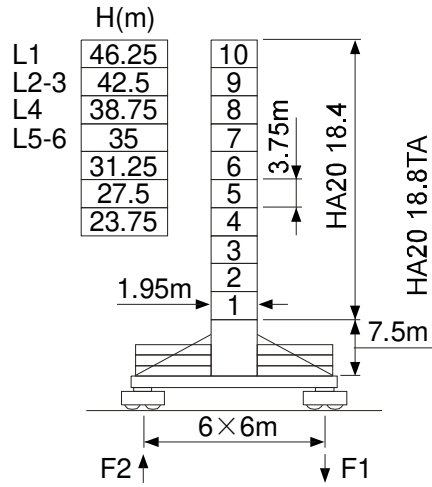

T4-F4

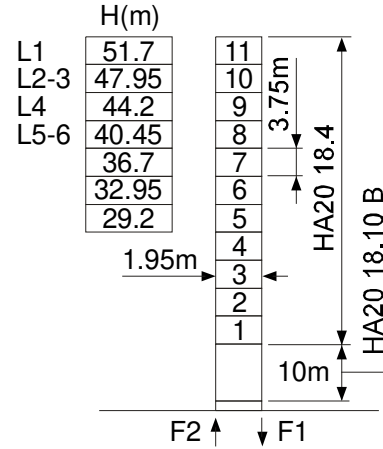

R4

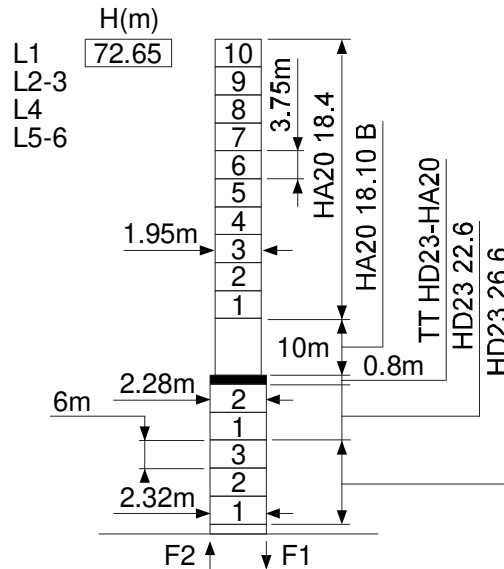





R5

※ 请联系我们 Please consult us.

● 工作状态 In service F 反力 Reactions ■ 非工作状态 Out of service ☂ 自重 Without load and ballast with longest jib and maximum height

Jt L180 G16 H20

负荷特性 Load diagrams

				m	15	20	25	30	35	40	45	50	55
8t	-	25.5m	t	8	8	8	6.33	4.97	3.95	3.15	2.52	2	
8t	-	28.6m	t	8	8	8	7.46	5.9	4.73	3.82	3.1		
12t	-	20.5m	t	12	12	9.19	7.06	5.54	4.4	3.51	2.8		
8t	-	29.7m	t	8	8	8	7.9	6.31	5.12	4.2			
12t	-	21.2m	t	12	12	9.7	7.53	5.97	4.8	3.9			
8t	-	29.3m	t	8	8	8	7.75	6.18	5				※
12t	-	22m	t	12	12	10.1	7.97	6.38	5.2				
16t	-	17.1m	t	16	13.2	9.96	7.75	6.18	5				
8t	-	29.8m	t	8	8	8	7.95	6.4					※
12t	-	22.2m	t	12	12	10.3	8.16	6.6					
16t	-	17.2m	t	16	13.3	10.1	7.95	6.4					
8t	-	30m	t	8	8	8	8						
12t	-	22.9m	t	12	12	10.8	8.6						
16t	-	17.7m	t	16	13.9	10.6	8.4						

※ = +500kg (  40m-35m)

内爬与附着 Climbing & Anchorages

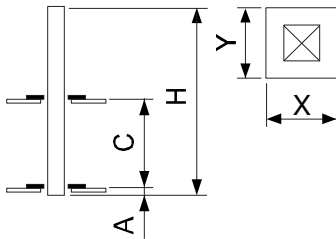

		H20 (m)											
		L1	L2-3	L4-5	L6	L1	L2-3	L4-5	L6	L1	L2-3	L4-5	L6
C min		14				12				10			
H max		48.75	45	41.25	37.5	45	41.25	37.5	33.75	33.75	30	30	26.25
A min		1											
X		2.6											
Y		2.08											

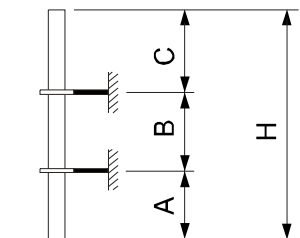



		H20 R4 (m)			
		L1	L2-3	L4-5	L6
A min/max		25/42	25/42	25/36	25/33
B min/max		18.75/22.5	18.75/22.5	18.75/22.5	18.75/22.5
C max		34	31	28	25
H max		※			

※ 请联系我们 Please consult us.

Jt L180 G16 H20

机构 Mechanisms

			m/min	t	kW	绕绳量 Rope length
起升 Hoisting	100LVF40		0~48	8	75kW	620m >620m※
			48~96	4		
			0~36	12		
			36~72	6		
			0~24	16		
			24~48	8		
拉臂 Luffing	※	※		※		
回转 Slewing	RCV145	0~0.8r/min		2×145Nm		
行走 Traveling	※					
380V(+6%~10%) 50Hz			※			

※ 请联系我们 Please consult us.



Jt L180 G16 HD23

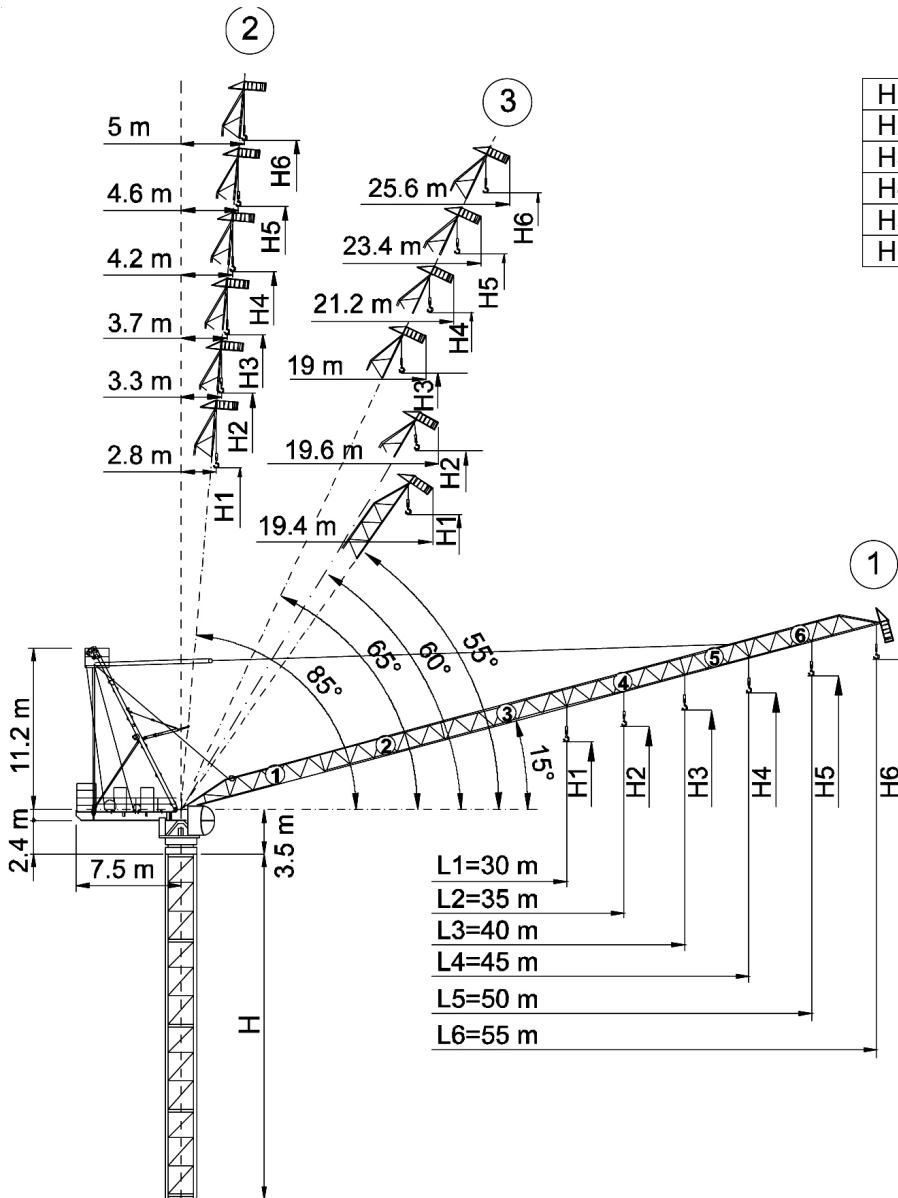

	H		
	①	②	③
H1	H+8.1	H+28.8	H+23.3
H2	H+9.4	H+34	H+29.2
H3	H+10.7	H+39.2	H+35.4
H4	H+12.1	H+44.4	H+40.1
H5	H+13.4	H+49.5	H+44.8
H6	H+14.7	H+54.6	H+49.5

L1	30m=1+2+6
L2	35m=1+2+5+6
L3	40m=1+2+3+6
L4	45m=1+2+3+5+6
L5	50m=1+2+3+4+6
L6	55m=1+2+3+4+5+6

H	Tower height 塔身高度
①	Maximum jib 最大臂长
②	Minimum jib(in service) 最小臂长 (工作状态)
③	Minimum jib(out of service) 最小臂长 (非工作状态)

Jt L180 G16 HD23

塔身 Masts

HD23

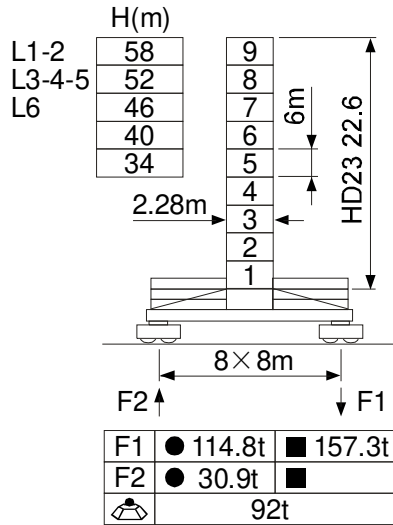

FP1

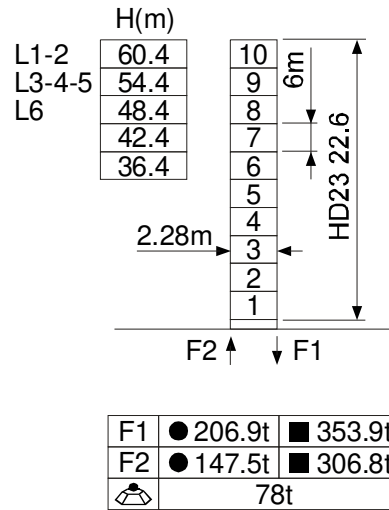

R1

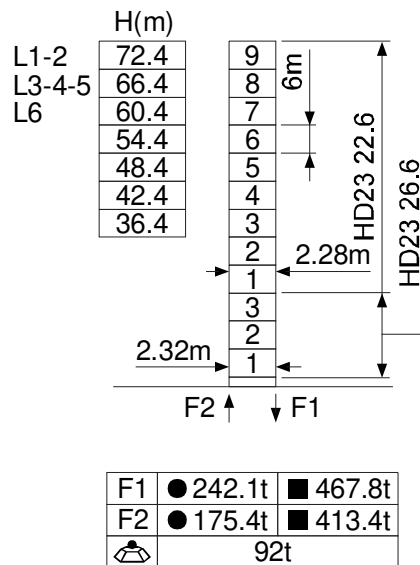

R2

※ 请联系我们 Please consult us.

● 工作状态 In service F 反力 Reactions ■ 非工作状态 Out of service 🏗️ 自重 Without load and ballast with longest jib and maximum height

Jt L180 G16 HD23

负荷特性 Load diagrams

					m	15	20	25	30	35	40	45	50	55
8t	- 25.5m	t	8	8	8	6.33	4.97	3.95	3.15	2.52	2			
8t	- 28.6m	t	8	8	8	7.46	5.9	4.73	3.82	3.1				
12t	- 20.5m	t	12	12	9.19	7.06	5.54	4.4	3.51	2.8				
8t	- 29.7m	t	8	8	8	7.9	6.31	5.12	4.2					
12t	- 21.2m	t	12	12	9.7	7.53	5.97	4.8	3.9					
8t	- 29.3m	t	8	8	8	7.75	6.18	5	※					
12t	- 22m	t	12	12	10.1	7.97	6.38	5.2						
16t	- 17.1m	t	16	13.2	9.96	7.75	6.18	5						
8t	- 29.8m	t	8	8	8	7.95	6.4	※						
12t	- 22.2m	t	12	12	10.3	8.16	6.6							
16t	- 17.2m	t	16	13.3	10.1	7.95	6.4							
8t	- 30m	t	8	8	8	8								
12t	- 22.9m	t	12	12	10.8	8.6								
16t	- 17.7m	t	16	13.9	10.6	8.4								

※ = +500kg (40m-35m)

内爬与附着 Climbing & Anchorages

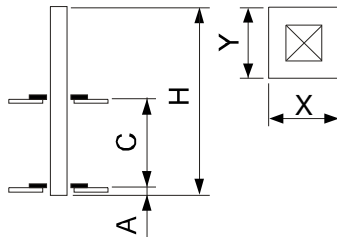

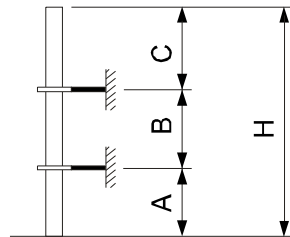

※ 请联系我们 Please consult us.



※ 请联系我们 Please consult us.

Jt L 18 0 G16 HD2 3

机构 Mechanisms

			m/min	t	kW	绕绳量 Rope length
起升 Hoisting	100LVF40		0~48	8	75kW	620m >620m※
			48~96	4		
			0~36	12		
			36~72	6		
			0~24	16		
			24~48	8		
拉臂 Luffing	※	※	※			
回转 Slewing	RCV145	0~0.8r/min	2×145Nm			
行走 Traveling	※					
380V(+6%~10%) 50Hz			※			

※ 请联系我们 Please consult us.



Jt L320 H24

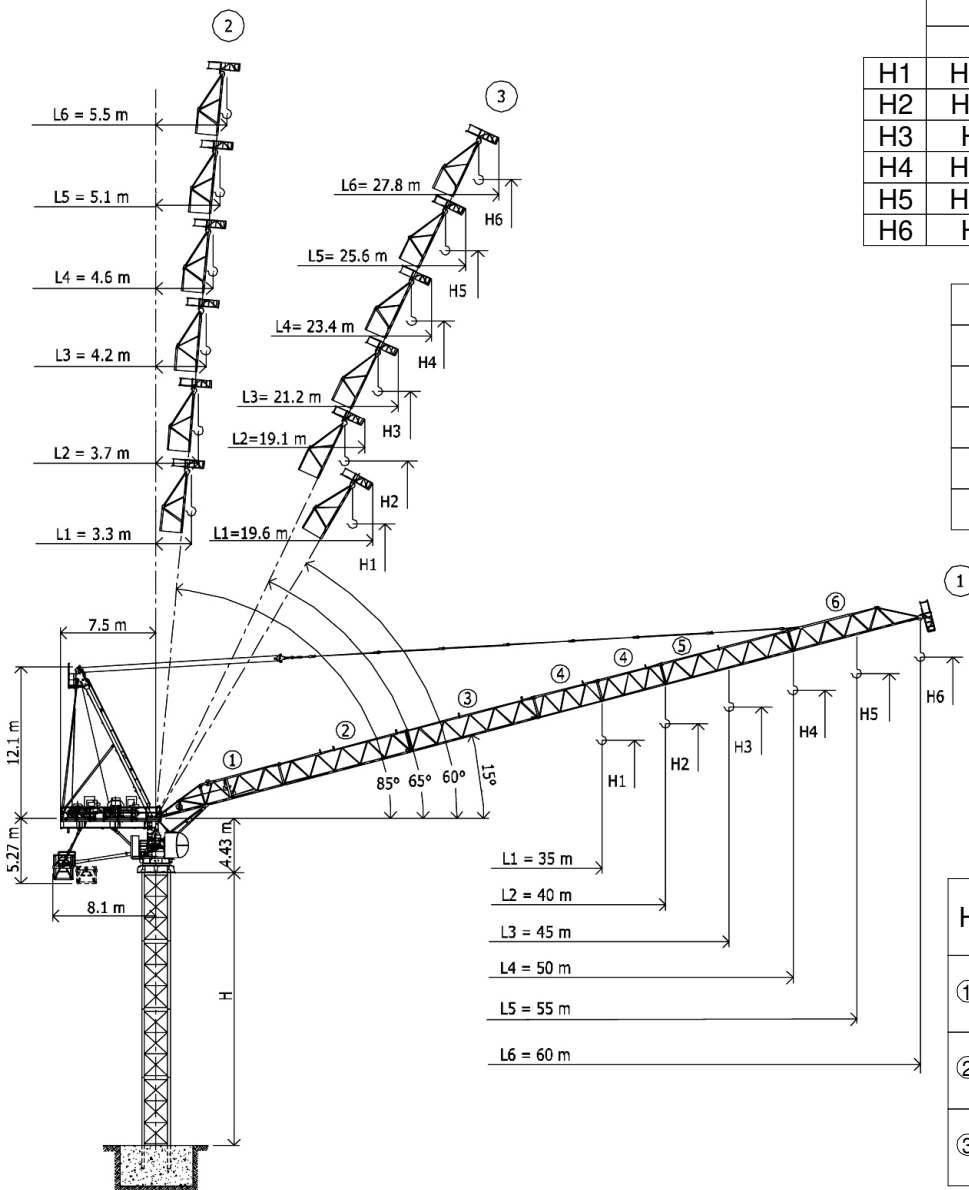

	H		
	①	②	③
H1	H+10.3	H+34.9	H+30.2
H2	H+11.7	H+40.1	H+36.4
H3	H+13	H+45.3	H+41.1
H4	H+14.4	H+50.4	H+45.7
H5	H+15.7	H+55.6	H+50.4
H6	H+17	H+60.7	H+55.1



L1	35m=1+2+4+6
L2	40m=1+2+3+6
L3	45m=1+2+3+4+6
L4	50m=1+2+3+5+6
L5	55m=1+2+3+4+5+6
L6	60m=1+2+3+4+4+5+6

L1	35 m
L2	40 m
L3	45 m
L4	50 m
L5	55 m
L6	60 m

H	Tower height 塔身高度
①	Maximum jib 最大臂长
②	Minimum jib(in service) 最小臂长 (工作状态)
③	Minimum jib(out of service) 最小臂长 (非工作状态)

Jt L320 H24

负荷特性 Load diagrams

		m	10	15	20	25	30	35	40	45	50	55	60
12t	- 21.3m	t	12	12	12	10.1	8.42	7.15	6.21	5.47	4.88	4.4	4
12t	- 24.4m	t	12	12	12	11.7	9.7	8.25	7.17	6.32	5.65	5.1	
18t	- 16.3m	t	18	18	14.5	11.5	9.5	8.06	6.97	6.12	5.45	4.9	
12t	- 27.4m	t	12	12	12	12	10.9	9.32	8.1	7.15	6.4		
24t	- 13.7m	t	24	21.9	16.2	12.8	10.5	8.93	7.71	6.76	6		
12t	- 29.4m	t	12	12	12	12	11.7	10	8.71	7.7			
24t	- 14.7m	t	24	23.5	17.4	13.8	11.3	9.62	8.3	7.3			
12t	- 30.9m	t	12	12	12	12	12	10.5	9.2				
24t	- 15.5m	t	24	24	18.4	14.5	12	10.1	8.8				
12t	- 31m	t	12	12	12	12	12	10.8					
24t	- 15.8m	t	24	24	18.8	14.8	12.2	10.4					

内爬与附着 Climbing & Anchorages

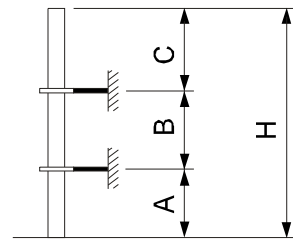
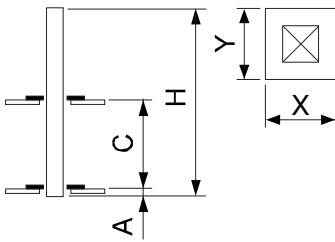



※ 请联系我们 Please consult us.

	HD23			
	(m)			
	L1	L2-3	L4	L5-6
A min/max	36/48	36/42	36/42	30/36
B min/max	24/30	24/30	24/30	24/30
C max	30	30	28	26
H max	※			

※ 请联系我们 Please consult us.

Jt L320 H24

机构 Mechanisms

			m/min	t	kW	绕绳量 Rope length
起升 Hoisting	125LVF160		0~58m/min	7.6	2×45kW	560m >560m※
			0~29m/min	16		
			0~38m/min	11.4		
			0~19m/min	24		

拉臂 Luffing	※	※	※
回转 Slewing	2×RCV185	0~0.7m/min	2×185Nm
行走 Traveling	※		

※ 请联系我们 Please consult us.